

Matrix-Assisted Laser Desorption/Ionization Mass Spectrometry of Biopolymers

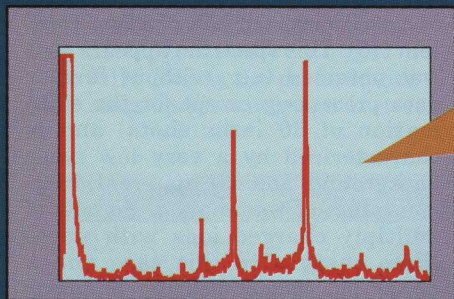

Franz Hillenkamp and Michael Karas

Institut für medizinische Physik und Biophysik
Universität Münster
Robert-Koch-Str. 31
D-4400 Münster
Germany

Ronald C. Beavis¹ and Brian T. Chait

The Rockefeller University
1230 York Avenue
New York, NY 10021

¹ Present address: Department of Physics, Memorial University of Newfoundland, St. Johns, Newfoundland, Canada A1B 3X7

Analytical chemists and biochemists have long sought accurate, sensitive methods for determining the molecular masses of biopolymers such as proteins and carbohydrates. Traditional mass spectrometric methods, which proved so useful for measuring compounds with low molecular

masses, were of little use for measuring underivatized compounds with high molecular masses. These methods require that the biopolymer molecules normally present in the condensed phase be converted into intact, isolated ionized molecules in the gas phase. This conversion is difficult to achieve because biopolymers are polar and massive and therefore extremely nonvolatile. During the past two decades, a remarkable array of volatilization and ionization techniques has been developed to address this problematic conversion step.

These new ionization techniques include those that produce the conversion by the application of a high electric field to the sample (field desorption [1]); by bombardment of the sample with energetic ions or atoms (²⁵²Cf plasma desorption [2] and secondary ion MS [3]); by the formation of ions directly from small, charged liquid droplets (thermospray ionization [4] and electrospray ionization [5]); and by bombardment with short-

duration, intense pulses of laser light (laser desorption, or LD [6, 7]).

Of these techniques, electrospray ionization and matrix-assisted laser desorption/ionization (LDI) (8), a newly developed version of LD, appear to hold the greatest promise for the mass spectrometric analysis of biopolymers in the molecular mass range between a few thousand and a few hundred thousand Daltons. In this INSTRUMENTATION article we provide an overview of matrix-assisted LDI, particularly its principles, instrumentation, and application to biopolymer analysis. Because we are on a very steep portion of the learning curve in this new area, readers should regard this article as an interim report.

History of LD and development of matrix-assisted LDI

Since the early 1960s lasers have been used to generate ions, including those of organic molecules, for analysis in mass spectrometers (9). Researchers

have used a variety of lasers with vastly different wavelengths (ranging from the far-UV to the far-IR) and pulse widths (ranging from picoseconds to CW irradiation) and combined them with virtually every available type of mass spectrometer. Considering the large variation in basic parameters, it is not surprising that different results have been obtained and that different combinations of lasers and spectrometers have evolved for applications such as trace analysis in inorganic and organic samples, microanalysis with a submicrometer spatial resolution, and molecular spectroscopy by laser postionization of neutrals in the gas phase. Cotter (6) and Hillenkamp and Ehring (7) have published more complete reviews of the LD field with extensive references. In this article we discuss the use of lasers to generate and analyze ions of large biomolecules, which has turned out to be one of the most fascinating laser applications in MS.

The first systematic attempts to generate ions of organic molecules with lasers date to the early 1970s (10, 11). After more than two decades of systematic observations, two general principles have evolved.

First, efficient and controllable energy transfer to the sample requires resonant absorption of the molecule at the laser wavelength. Consequently, lasers emitting in the far-UV, which can couple to electronic states, or in the far-IR, which can excite rovibrational states, give the best results.

Second, to avoid thermal decomposition of the thermally labile molecules, the energy must be transferred within a very short time. Typically, lasers with pulse widths in the 1–100-ns range, such as Q-switched Nd:YAG, excimer, or TEA-CO₂, are used. Given these short durations and the fact that laser beams can easily be focused to spot sizes that are small compared with the other dimensions of the ion source, the ions are generated essentially at a point source in space and time. This feature makes them ideally suited to be combined with time-of-flight (TOF) mass spectrometers.

All early experiments on LD of organic ions, however, revealed an upper limit to the size of molecules that could be desorbed as intact ions. This limit, which depended on molecular structure and laser parameters, was ~1000 Da for biopolymers and up to 9000 Da for synthetic polymers.

For resonant desorption experiments, this limitation is believed to

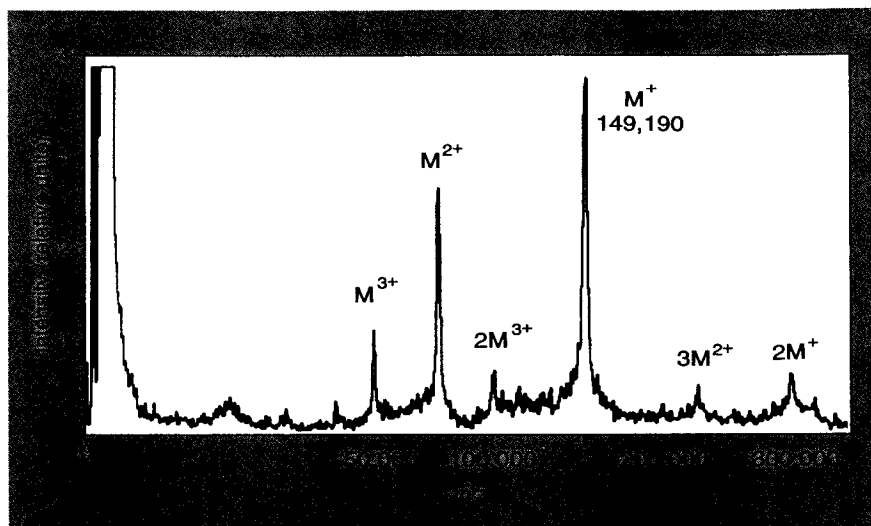

Figure 1. LDI mass spectrum of a monoclonal antibody from the mouse.

$M = 149,190 \pm 69$ Da. Matrix: nicotinic acid; laser wavelength: 266 nm. Spectrum taken with a reflectron TOF analyzer in the laboratory of the Münster group. The number of charges on each ion species is given by the superscript $n+$. Although this charge is believed to be in the form of attached protons, it could conceivably arise by removing electrons. (Adapted with permission from Reference 15.)

result primarily because the resonant excitation of the analyte molecules needed for the controllable, nonexplosive energy transfer also puts energy into photodissociation channels. In nonresonant desorption experiments the necessary irradiances are very close to the onset of plasma generation, which also destroys large organic molecules. The main breakthrough toward higher masses came when Hillenkamp and Karas' research group realized that the use of a matrix could circumvent this problem (12).

As the technique now stands, a low concentration of analyte molecules, which usually exhibit only moderate absorption per molecule, is embedded in either a solid or a liquid matrix consisting of a small, highly absorbing species (13, 14). In this way the efficient and controllable energy transfer is retained while the analyte molecules are spared from excessive energy that would lead to their decomposition. As a side effect, the dilution seems to prevent association of the analyte molecules that would otherwise lead to complexes of masses too large to be desorbed and analyzed. We also suspect that suitable matrices enhance the ion formation of the analyte molecules by photoexcitation or photoionization of matrix molecules, followed by proton transfer to the analyte molecule. This latter hypothesis, however, must be investigated further.

Figure 1 shows the spectrum of a monoclonal antibody of ~150,000 Da molecular mass as a typical example

of matrix-assisted LDI of a large protein (15). This spectrum appears as it was obtained (i.e., without further data processing except for the summation of 30 laser shots) and is characterized by a very low noise background and no apparent fragmentation of the analyte. Signals of multiply charged ions with up to three charges in this case and a dimer ion, demonstrating oligomer formation, are also typical features of LDI spectra. The spectrum will be discussed in more detail below.

Instrumentation

TOF mass spectrometers. The mass of an ion can be measured by using its velocity to determine the mass-to-charge ratio (m/z) by TOF mass analysis. In a TOF spectrometer, a packet of ions is accelerated to a fixed kinetic energy by an electric potential. The velocity of the ions will then be proportional to $(m_i/z_i)^{-1/2}$ where m_i/z_i is the mass-to-charge ratio of a particular ion species. The ions are then allowed to pass through a field-free region where they separate into a series of spatially discrete individual ion packets, each traveling with a velocity characteristic of its mass. A detector at the end of the field-free region produces a signal as each ion packet strikes it.

A recording of the detector signal as a function of time is a TOF mass spectrum. The difference between the start time, common to all ions, and the arrival time of an individual ion at the detector is proportional to $(m_i/z_i)^{+1/2}$ and therefore can be used

to calculate the ion's mass. Such a calculation can be used to convert the axis of the spectrum into a mass-to-charge ratio axis (i.e., a conventional mass spectrum).

Figure 2a is a diagram of a linear (i.e., straight flight path) TOF mass spectrometer with an LD ion source. The initial packet of ions is produced by a pulse of laser light absorbed by the sample. These ions are extracted and accelerated by the static electric field between the planar electrodes. The ions then pass through the field-free region and arrive at the front plane of the detector. This instrumental configuration was first applied to large-molecule MS by Macfarlane and Torgerson (2), who used a plasma desorption ion source. Many investigators subsequently used similar designs with a variety of electrode configurations, ion sources, and detectors (16–18). The acceleration voltages are typically 1–30 kV (positive or negative polarity), and the flight pathlengths range from 0.1 to 3 m.

To fully discuss the performance of TOF mass spectrometers, it is neces-

sary to define mass accuracy and mass resolution. These two important parameters are used to evaluate and compare the performance of different instrumental configurations. Mass resolution $m/\Delta m$ is a measure of an instrument's capability to produce separate signals from ions of similar mass. It is expressed as the mass m of a given ion signal divided by the full width of the signal Δm , which is measured between the points of half-maximum intensity for TOF instruments. Mass accuracy is a measure of the error involved in assigning a mass to a given ion signal. It is expressed as the ratio of the mass assignment error divided by the mass of the ion and is frequently quoted as a percentage.

The practical limitation of the mass resolution obtained with the mass spectrometer shown in Figure 2a is the width of a signal observed for a single ion species. The ion production time, initial velocity distribution, and extraction time all contribute to the width of the peak observed by the detector. The broadening caused by the ions' initial velocity distribution can be reduced by using an instrumental configuration such as the one shown in Figure 2b. In this instrument, an ion mirror as first proposed by Mamyrin and co-workers (19) is placed in the flight path of the ion packets. If the mirror electrode voltages are arranged appropriately, the peak width contribution from the initial velocity distribution can be largely corrected for at the plane of the detector. The correction leads to increased mass resolution for all stable ions in the spectrum. (Stable ions are those that do not dissociate in flight.) An instrument with an ion mirror configured in this manner is often referred to as a reflectron TOF mass spectrometer.

LD ion sources. Several different LD ion sources for TOF spectrometers have been described (13, 20–24). They all share the components illustrated in Figure 3. All ion sources use pulsed lasers with pulse durations of 1–200 ns. UV lasers, including N₂ (337 nm), excimer (193, 248, 308, and 351 nm), frequency-doubled excimer-pumped dye (220–300 nm) and Q-switched, frequency-tripled and quadrupled Nd:YAG (355 and 266 nm, respectively) as well as IR lasers (TEA-CO₂: 10.6 μ m and Er:YAG: ~3 μ m) have been employed to produce matrix-assisted LDI.

The light is focused with either a single or a multielement optical system and passed through a window into the mass spectrometer. The size

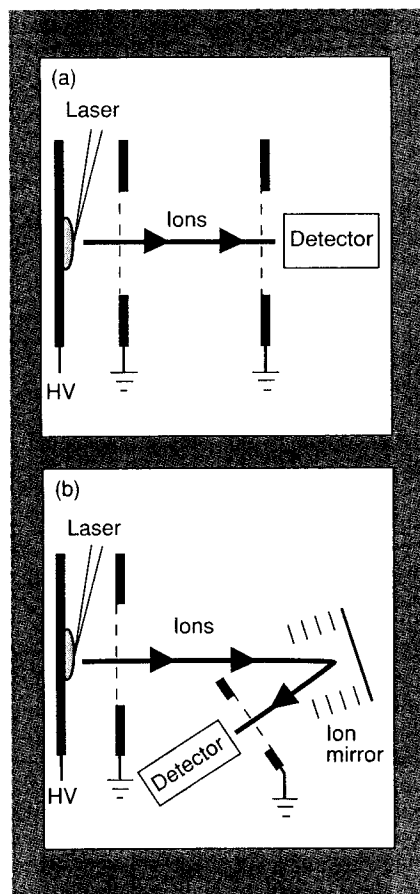

Figure 2. (a) Linear and (b) reflectron TOF mass spectrometers used for matrix-assisted LDIMS.

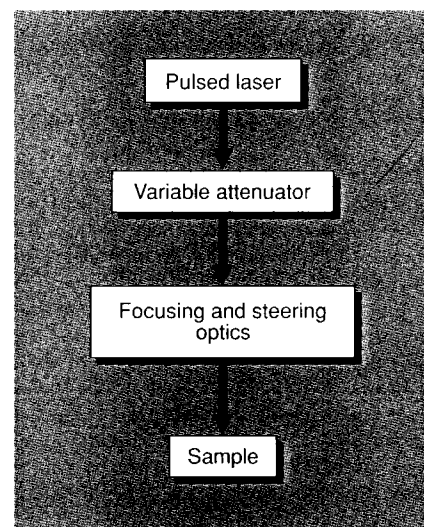

Figure 3. Block diagram of an LD ion source.

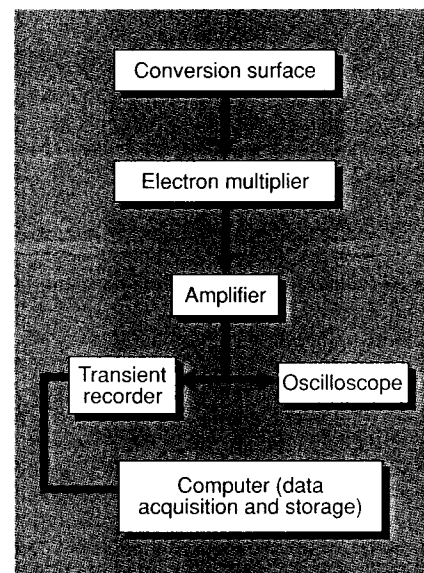

Figure 4. Block diagram of a TOF detector and data-recording electronics.

of the laser focus does not seem to be critical; beam spot diameters ranging from 10 to 300 μ m have been used to give qualitatively similar results. The angle of incidence of the laser beam on the sample surface has varied between 30° and 75° without significantly altering the ion signals produced. The position of the laser focus on the sample surface can be changed either by shifting the optical axis of the focusing system or by moving the sample beneath a fixed axis. (This latter strategy is used in laser microprobe instruments.)

A critical parameter in an ion source designed to perform matrix-assisted LDI is the irradiance of the

laser light at the sample. The minimum, or threshold, laser irradiance necessary to produce protein ions from a sample is $\sim 1 \text{ MW/cm}^2$ (a laser fluence of 10 mJ/cm^2 for a 10-ns laser pulse width [21]). This ion production threshold is sharp; near the threshold, ion production falls off to the fifth power of laser irradiance (25). The best results are obtained for a laser irradiance no more than $\sim 20\%$ above the threshold for ion production. Therefore an effort must be made to carefully control the laser intensity and the homogeneity of the beam profile at the sample surface. A variable attenuator in the laser optical path has been the most effective method for controlling the laser intensity.

Ion detection and data collection. A diagram with the major components for ion detection and data collection is shown in Figure 4. To be detected, the high-mass ions produced by matrix-assisted LDI must be converted into either electrons or low-mass ions at a conversion electrode. These electrons or low-mass ions are then used to start the electron multiplication cascade in an electron multiplier. The electrode, mounted at a right angle to the ion trajectory, must be relatively flat so that the ion flight pathlength is kept constant across the surface of the detector.

The yield of secondary electrons from the conversion electrode is a function of the velocity of the ions to be detected (26). The large ions generated by matrix-assisted LDI move too slowly to generate secondary electrons efficiently, but they do produce low-mass secondary ions from the surface (27) that are also effective for starting the electron multiplication cascade. The surfaces used for this conversion have been either copper-beryllium or the lead glass inner surface of a microchannelplate.

After ion conversion and initial electron multiplication (with either a discrete dynode electron multiplier or a microchannelplate), the detector signal is further amplified and impedance matched with a fast linear amplifier (bandwidth $> 100 \text{ MHz}$). The transient signal produced by a single laser shot can be viewed directly on an analog oscilloscope and stored in a transient digitizer/digital oscilloscope (bandwidth $> 100 \text{ MHz}$). Maintaining the fidelity of the signal from the detector to the final documentation is important when trying to achieve high mass accuracy measurements. The digitized data generated from successive laser shots can

Table I. Matrices for matrix-assisted LDIMS

Matrix	Form	Usable wavelengths
Nicotinic acid	Solid	266 nm, 2.94 μm , 10.6 μm
2,5-Dihydroxybenzoic acid	Solid	266 nm, 337 nm, 355 nm, 2.79 μm , 2.94 μm , 10.6 μm
Sinapinic acid	Solid	266 nm, 337 nm, 355 nm, 2.79 μm , 2.94 μm , 10.6 μm
Succinic acid	Solid	2.94 μm , 10.6 μm
Glycerol	Liquid	2.79 μm , 2.94 μm , 10.6 μm
Urea	Solid	2.79 μm , 2.94 μm , 10.6 μm
Tris buffer (pH 7.3)	Solid	2.79 μm , 2.94 μm , 10.6 μm

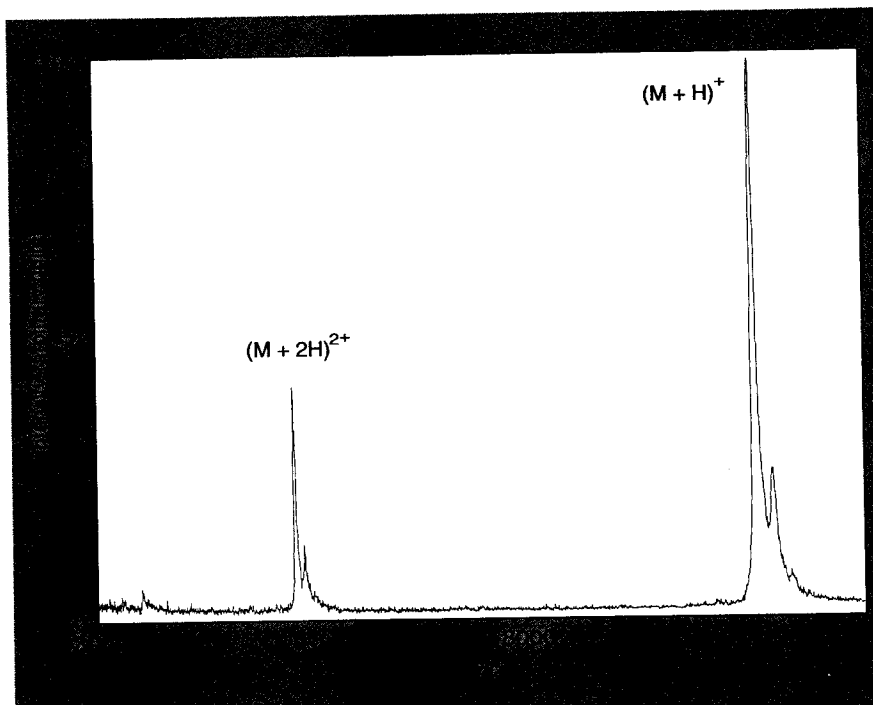

Figure 5. LDI mass spectrum of the protein ARPP-16.

Matrix: sinapinic acid; laser wavelength: 355 nm. Spectrum taken with a linear TOF analyzer in the laboratory of the New York group.

be summed, resulting in a TOF mass spectrum. Multiple shots are used to improve the signal-to-noise ratio and the peak shapes, thereby increasing the accuracy of the mass determination.

Matrices and sample preparation

The matrix is believed to serve two major functions: absorption of energy from the laser light and isolation of the biopolymer molecules from each other. Experimental results indicate that a molar ratio ranging from 100:1 to 50,000:1 of matrix to analyte is optimal for ion production. It is relatively simple to determine whether a

candidate matrix material will absorb efficiently at the laser wavelength. It is not possible, however, to predict a priori if a compound will form a homogeneous solid (or liquid) solution with a given analyte molecule, particularly in the presence of ionic contaminants. This difficulty has meant that the discovery of new matrix materials with desirable properties has been a matter of trial-and-error experimentation. A list of useful matrix compounds appears in Table I.

The preparation of samples for analysis is quite simple and fast. A 5–10-g/L solution of the matrix mate-

rial is prepared in either pure water or a water/organic (ethanol, acetonitrile) solvent; 0.1% trifluoroacetic acid is added in some cases. Suitable amounts of 10^{-5} – 10^{-6} M solutions of the analyte are then mixed with 5–10 μL of matrix solution to yield a final analyte concentration of 0.005–0.05 g/L in the mixture. An aliquot of 0.1–1 μL of the mixture is then applied to a sample probe and dried at room temperature. The sample is then ready to be loaded into the mass spectrometer and analyzed. Any inert metal can be used for the probe (e.g., stainless steel or silver).

When inspected under a microscope, samples prepared in this way appear to be heterogeneous. The most intense ion signals are usually associated with regions of the sample that appear crystalline, although this result depends on the matrix substance and the presence of buffers or detergents in the analyte sample. Recently a sample preparation method in which single crystals are grown from matrix-analyte mixtures was developed (28). A few liquid matrices (3-nitrobenzyl alcohol in the UV and glycerol and lactic acid in the IR) and matrices with physiological pH, such as Tris buffer (IR), are also available.

Current practical status

Linear and reflectron type mass spectrometers are being used for research in matrix-assisted LDI analysis of biopolymers and are also commercially available. Using a linear instrument, researchers reported that the best mass resolution for proteins is in the range of $m/\Delta m = 300$ –500 with mass accuracies of 0.01% (29). Reflectron analyzers have demonstrated higher mass resolution for polypeptides ($m/\Delta m > 3000$ [30]) and for proteins with molecular masses up to 12,000 Da ($m/\Delta m = 1200$ [31]).

The greatest analytical strength of the technique seems to be that it can be applied to any protein, with a practical sensitivity of ~ 1 pmol of protein loaded into the instrument. A sensitivity of 1 fmol loaded into the instrument also has been demonstrated under favorable conditions (28). The amount of material consumed for the analysis is much less than the amount loaded into the instrument.

No limitation on application caused by primary, secondary, or tertiary protein structure has yet been discovered. Proteins with widely divergent solution-phase properties, including proteins that are insoluble in ordinary aqueous solutions and

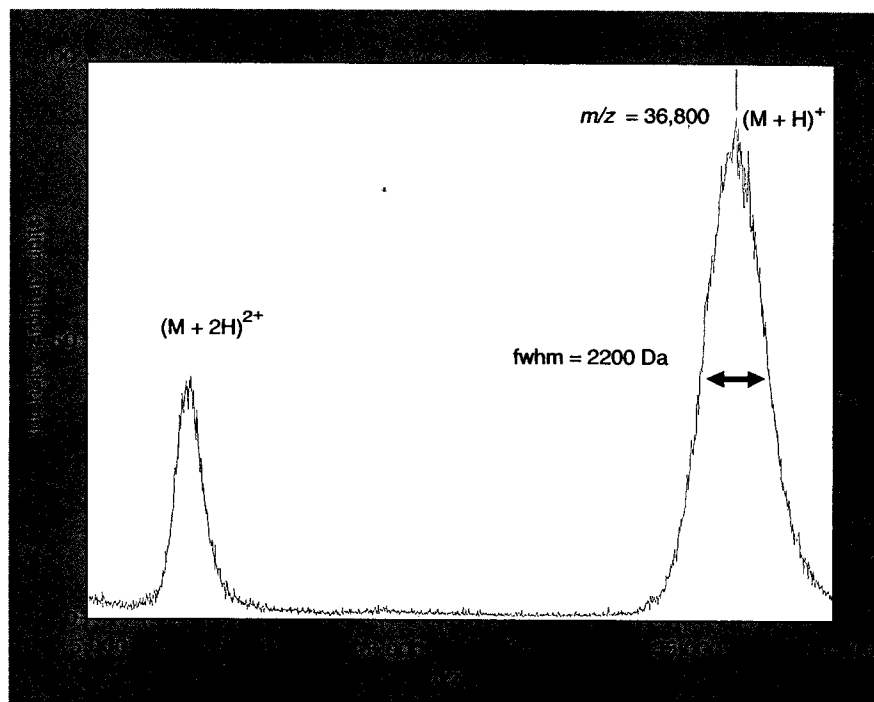

Figure 6. LDI mass spectrum of α_1 acid glycoprotein.

Matrix: sinapinic acid; laser wavelength: 355 nm. Spectrum taken with a linear TOF analyzer in the laboratory of the New York group.

glycoproteins that contain large mass fractions of carbohydrate, can be analyzed. Other groups of biopolymers, such as polynucleotides, underivatized oligosaccharides, and glycolipids, can also be investigated.

A significant consideration is the length of time necessary to analyze a sample. Sample preparation takes several minutes, using the protocol described above. The time necessary to load a sample into the instrument varies between 5 and 15 min, depending on the vacuum system of the mass spectrometer. The time to actually accumulate a spectrum consisting of the sum of repeated laser shots is ~ 100 s.

One important feature of the technique is that for some matrices, such as sinapinic acid (*trans*-3,5-dimethoxy-4-hydroxycinnamic acid) or 2,5-dihydroxybenzoic acid (DHB), relatively high concentrations of inorganic and organic contaminants do not strongly affect the analysis. Buffer and salt concentrations normally used in biochemical procedures do not have to be removed before analysis. When using DHB, one can tolerate up to 0.1 g/mL contamination of sodium dodecyl sulfate (SDS) in the protein solution (28). Exposure of a protein to ionic detergents at any step during its purification, however, may lead to nearly irreversible binding of the detergent to the protein

and thus may adversely affect ion production. Anionic detergents can be removed by the extraction procedure suggested by Henderson and co-workers (32). Nonvolatile solvents (e.g., glycerol or dimethylsulfoxide) seem to prevent ion desorption for all solid matrices tested thus far with UV wavelengths. By itself, however, glycerol is an excellent IR matrix.

The major limitation of using the technique as an analytical tool is the presence of satellite adduct peaks on the ion signals from the protonated protein molecules (21). These adduct signals appear at slightly greater mass than the protein and are caused by the addition of photochemically generated fragments of the matrix material attached to the protein. The intensity of such adduct peaks increases with increasing protein molecular mass. The intensity of the adduct peaks is also strongly dependent on the matrix substance chosen (e.g., nicotinic acid produces very intense satellites compared with those of sinapinic acid or 2,5-dihydroxybenzoic acid). The adduct peaks also become more difficult to resolve from the protonated ion peak for larger mass proteins and, therefore, the two signals begin to merge. This combination of the two peaks leads to systematic mass assignment errors.

A limited fragmentation that depends on the matrix, the laser wave-

length, and, in particular, the laser irradiance, and appears to increase with increasing molecular mass, has also been observed (33). In reflectron instruments such fragments appear at lower (and not necessarily correct) masses and will, if not resolved, also lead to erroneous mass assignments. Both effects can also interfere with the detection of protein modifications that produce small molecular mass differences and are stoichiometrically rare, such as protein phosphorylation.

Applications

Analysis of proteins. Matrix-assisted LDI mass spectra of proteins are often simple in appearance. The spectrum of a monoclonal antibody in Figure 1 is a typical example. It is dominated by peaks corresponding to the singly and doubly protonated intact proteins. Singly and multiply charged oligomer ions are also frequently observed. The primary information that can be deduced from these spectra is the proteins' molecular masses, which are obtained by taking centroids of the peaks and computing an average value with a standard deviation, taking into account the fact that they should all be integer multiples or fractions of each other.

The average mass of $149,190 \pm 69$ Da in Figure 1 was obtained by using all six assigned peaks; the standard deviation, therefore, represents the precision, not the (absolute) accuracy of the mass measurement. The technique is valuable for applications requiring molecular mass determinations, such as initial characterization of proteins whose primary structures are not known, the confirmation of the correctness of a previously determined protein sequence, and the detection and elucidation of post-translational modifications in proteins.

Figure 5 shows the matrix-assisted LDI mass spectrum of ARPP-16, a cAMP-regulated phosphoprotein purified from the soluble fraction of bovine caudate nuclei (34). The suffix after ARPP refers to the apparent molecular mass of the protein (16 kDa) as determined by sodium dodecyl sulfate polyacrylamide gel electrophoresis (SDS-PAGE), a widely used method for inferring molecular weights of protein subunits (35). The sequence of the protein was inferred from the cDNA sequence, and the amino-terminus was blocked by an unknown moiety.

The mass spectrum exhibits two intense peaks corresponding to the singly and doubly protonated intact

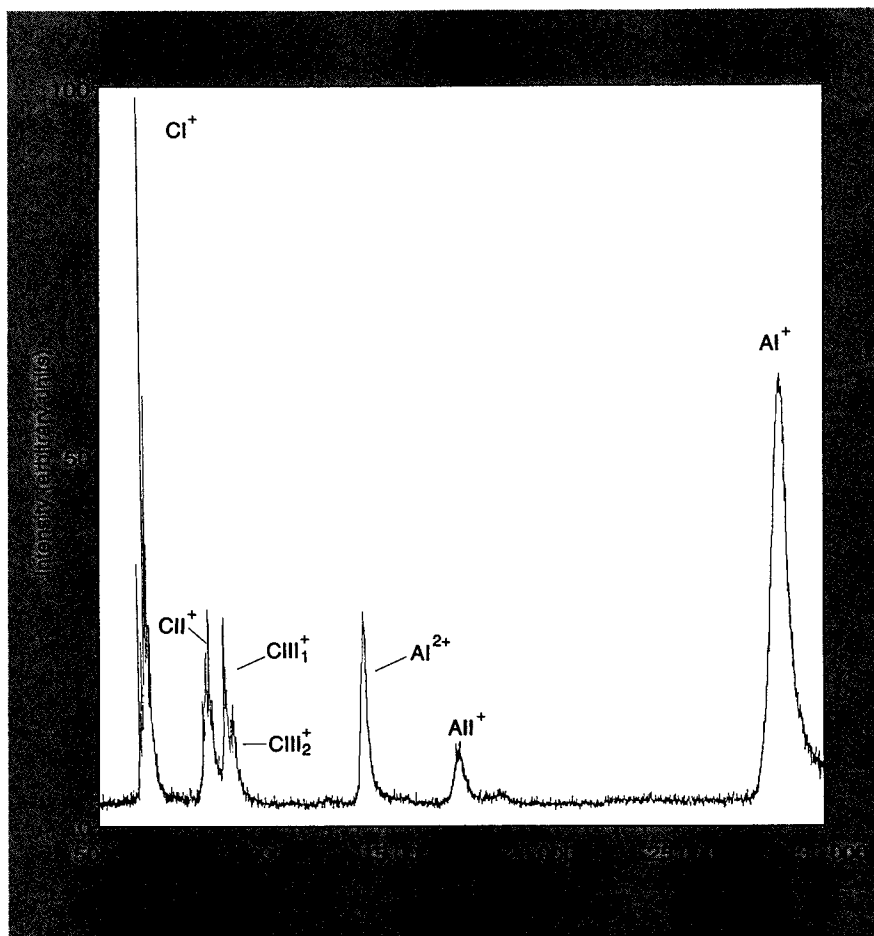

Figure 7. LDI mass spectrum of lipoproteins obtained from a delipidated high-density lipoprotein fraction of human plasma.

Matrix: sinapinic acid; laser wavelength: 355 nm. Spectrum taken with a linear TOF analyzer in the laboratory of the New York group. The number of charges on each ion species is given by the superscript $n+$. Although this charge is believed to be in the form of attached protons, it could conceivably arise by removing electrons. (Adapted from Reference 37.)

protein. The average of the two measurements yields a molecular mass of 10,708.8 Da. This measured mass is much lower than that determined by SDS-PAGE but quite close to that inferred from the cDNA sequence ($M = 10,665.2$ Da). The difference between the measured and the calculated masses is 43.6 Da, a value consistent (within the uncertainty of the measurement) with the presence of an acetyl blocking group at the amino terminus. This detailed information was obtained rapidly (in < 15 min) from a total quantity of 1 pmol of protein in the presence of a large molar excess of buffer.

Proteins containing large proportions of carbohydrate have proven quite refractory to mass spectrometric analysis. Such glycoproteins, however, produce intense spectra under matrix-assisted LDI. Figure 6 shows the spectrum obtained from α_1 acid glycoprotein, a human blood plasma protein containing ~40% by

weight of carbohydrate. The oligosaccharides are asparagine linked and of the complex form containing a large total number of sialic acid moieties. The spectrum is dominated by peaks corresponding to the singly and doubly protonated glycoprotein.

Unlike the previous example, these peaks are extremely broad and reflect the large amount of heterogeneity in the carbohydrate portion of the molecule. The resolution of the mass spectrometer used to obtain this spectrum ($m/\Delta m = 300$) was insufficient to permit resolution of the individual glycoprotein components. However, the difference between the average mass of the molecule (deduced from the centroids of the broad peaks) and the mass of the peptide backbone (calculated from the known amino acid sequence) gives a measure of the average mass of carbohydrate attached to the protein. The width of the peaks gives a measure of the amount of heterogeneity in the com-

pound. Treatment of the compound with glycosidases and subsequent re-measurement of the molecular mass yields information concerning the number of particular types of sugars that are cleaved by the enzymes. A considerable amount of information concerning the makeup of glycoproteins can be rapidly deduced from analyzing picomolar amounts of such compounds.

The analysis of protein mixtures provides an especially important and difficult challenge for MS users. The use of certain matrices (e.g., sinapinic acid [36]) has greatly facilitated the analysis of complex protein mixtures. Figure 7 shows an example of a mass spectrum obtained from the unfractionated biological mixture of proteins in the high-density lipoprotein fraction of human plasma (37). The absence of fragment ions and the dominance of singly and doubly protonated intact protein ions make the interpretation of such spectra particularly straightforward.

Mass determination of the spectral peaks with an accuracy of $\sim 0.01\%$ makes it possible to characterize all the major proteins and glycoproteins

in the mixture. Most intense peaks in Figure 7 have been assigned to known components of the high-density lipoprotein fraction (38) by their observed molecular mass, as indicated in the figure. The extent of glycosylation (such as the set of CIII proteins CIII₁⁺ and CIII₂⁺) can be readily assessed. Any mass shift or peak twinning of the known protein components would indicate the presence of genetic variants or protein modifications.

Other important classes of peptide or protein mixtures that can be analyzed by this method include those generated by chemical or enzymatic digestion of proteins and those produced by inadequate purification of the protein of interest. The former class of mixture is frequently generated to aid in the structural elucidation of peptides (37-40) and to study the action of enzymes on natural protein substrates (41). Analysis of the latter class of mixture is important for assessing the purity of a protein preparation and determining whether it is derived from native sources, produced by recombinant technology, or produced by solid-

phase synthetic methods.

Under special conditions, the quaternary structure of a protein can be reflected in matrix-assisted LDI spectra. Most examples have been obtained with a nicotinic acid matrix using pure water as a solvent. Proteins such as glucose isomerase ($M = 172$ kDa) and streptavidin ($M = 52$ kDa), which are tetramers of identical noncovalently bound subunits, have been desorbed as intact tetramers. The spectra yield the typical pattern with a singly charged (tetramer) ion as the base peak, peaks corresponding to the multiply charged tetramer (some of which overlap with the subunit signals of M_{SU}), and singly and multiply charged oligomers.

Figure 8 shows a matrix LDI mass spectrum of porin, a membrane protein from *Rhodobacter capsulatus*. This protein forms a stable noncovalent trimer that is observed in the mass spectrum; strong signals at one and two-thirds of the trimer mass indicate partial dissociation into the subunits. Dissociation can be enhanced and completed by adding an organic solvent such as ethanol to the protein solution.

Other classes of biopolymers.

Most experience with matrix-assisted LDIMS has involved the use of proteins, but this technique is by no means restricted to this class of biopolymers. In preliminary experiments natural polynucleotides with molecular masses of up to 38,000 Da (5S-RNA) have been successfully analyzed (42). Mixtures of synthetic oligonucleotides $\{[d(pT)]_{12}-[d(pT)]_{18}\}$ have also been resolved in UV and IR LDI spectra.

Natural, underivatized oligosaccharides are also amenable to matrix-assisted LDI (43, 44). Spectra of oligomeric distributions of dextrans and dextrans, as well as signals of glycolipids, have been obtained. These analyses were performed at a wavelength of 337 nm, with 2,5-dihydroxybenzoic acid as the matrix. Cationization rather than protonation was observed. For these classes of biopolymers the mass range has, as yet, been extended to only ~15,000 Da. Future work, particularly with regard to searching for new matrices and optimizing sample preparation procedures to exploit the potential of matrix-assisted LDI for these compounds, is undoubtedly necessary.

Future developments

Until recently, all the instruments on which matrix-assisted LDI studies have been carried out were constructed in the laboratories of individual investigators. The limited availability of the requisite instrumentation has limited the number of problems to which matrix-assisted LDI has been applied. The recent introduction of commercial instrumentation is expected to greatly increase the applicability of the method and lead to improvements in the practical aspects of the technique.

There is a need to improve matrices so that they produce no adduct ion to the compounds under study, induce a minimum of metastable decay, produce increasingly higher ionization efficiencies, and can be used reliably with a wide range of compound types such as synthetic polymers, carbohydrates, and DNA.

It is also highly desirable that the resolution limit of 300–500 fwhm obtained in the currently available TOF instrumentation for large biopolymers be increased to between 1000 and 4000 fwhm (i.e., to the resolution limit imposed by the envelope of the isotope distribution) in the full mass range of interest.

A key to the sensitive, rapid mass spectrometric analysis of biomolecules will be the ability to handle,

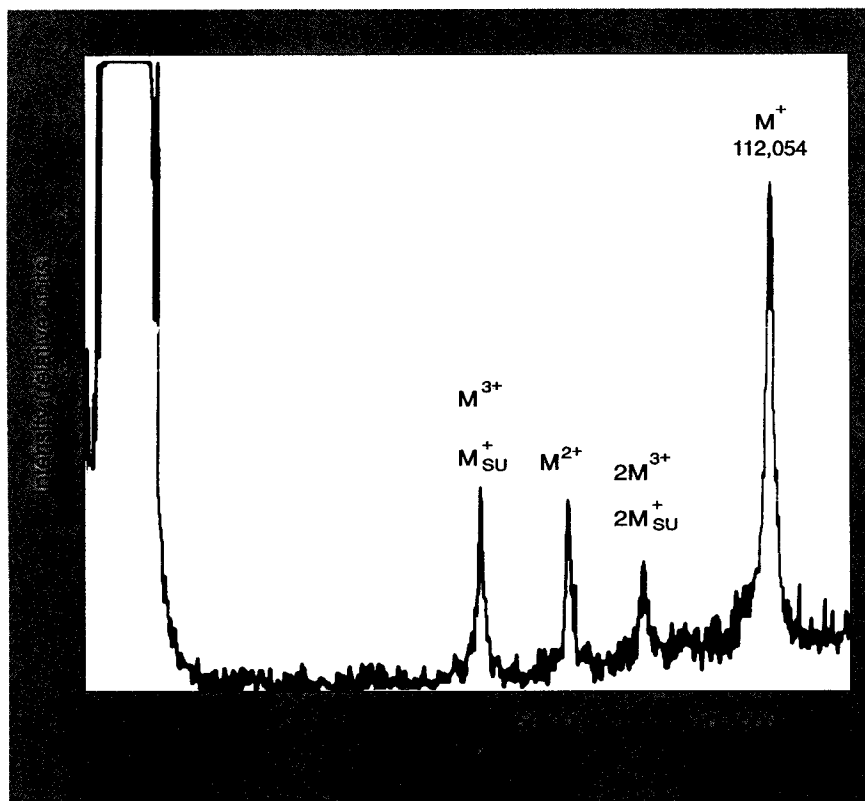

Figure 8. LDI mass spectrum of porin, a membrane protein from *Rhodobacter capsulatus*.

$M = 112$ kDa. Matrix: nicotinic acid; laser wavelength: 266 nm. Spectrum taken with a reflectron TOF analyzer in the laboratory of the Münster group. The number of charges on each ion species is given by the superscript $n+$. Although this charge is believed to be in the form of attached protons, it could conceivably arise by removing electrons.

without severe loss, very small quantities of material and to provide a convenient means for coupling the various available wet separation techniques to the LDI mass spectrometer. Thus it is envisaged that microbore LC or capillary zone electrophoresis separation systems will be coupled to the LDI mass spectrometer. The coupling may be made either on line through an injection system directly into the vacuum (e.g., through a particle beam) or off line on surfaces that can be loaded into the mass spectrometer for subsequent interrogations. One might also envisage a direct 2D laser scan of a 2D gel electrophoretic separation of a complex protein mixture.

It has been suggested that matrix-assisted LDIMS ultimately may be used for the ultrarapid sequence analysis of DNA fragments. In this scheme the mass spectrum will take the place of conventional separation gels to order the fragments produced by the Sanger dideoxy- or Maxam-Gilbert methods.

In the future, the matrix-assisted LDI source may prove useful in combination with mass analyzers other

than the TOF analyzer, especially for the analysis of peptides and relatively small proteins. Potentially useful analyzers for this purpose include the double-focusing magnetic deflection instrument fitted with an integrating array detector, the Fourier transform mass analyzer, and the quadrupole ion trap analyzer.

References

- (1) Beeky, H. D. *Principles of Field Desorption Mass Spectrometry*; Pergamon Press: Oxford, 1977.
- (2) Macfarlane, R. D.; Torgerson, D. F. *Science* **1976**, *191*, 920.
- (3) (a) Benninghoven, A.; Sichtermann, W. K. *Anal. Chem.* **1978**, *50*, 1180. (b) Barber, M.; Bordoli, R. S.; Sedgwick, R. S.; Tyler, A. N. *J. Chem. Soc. Chem. Commun.* **1981**, 325.
- (4) Blakely, C. R.; Carmody, J. J.; Vestal, M. L. *Anal. Chem.* **1980**, *52*, 1636.
- (5) Whitehouse, C. M.; Dreyer, R. N.; Yamashita, M.; Fenn, J. B. *Anal. Chem.* **1985**, *57*, 675.
- (6) Cotter, R. J. *Anal. Chim. Acta* **1987**, *195*, 45–59.
- (7) Hillenkamp, F.; Ehring, H. In *Mass Spectrometry in the Biological Sciences: A Tutorial*; Gross, M. L., Ed.; Kluwer Academic Publishers: Dordrecht, The Netherlands, in press.
- (8) Karas, M.; Hillenkamp, F. In *Advances*

- in *Mass Spectrometry*; Longevialle, P., Ed.; Heyden & Son: London, 1989; pp. 416-17.
- (9) Vastola, F. J.; Mumma, R. O.; Pirone, A. J. *Org. Mass Spectrom.* **1970**, *3*, 101-04.
- (10) Posthumus, M. A.; Kistemaker, P. G.; Meuzelaar, H.L.C.; ten Neuver de Brauw, M. C. *Anal. Chem.* **1978**, *50*, 985-91.
- (11) Kupka, K.-D.; Hillenkamp, F.; Schiller, C. *Advances in Mass Spectrometry*; Heyden & Sons: London, 1980, Vol. 8A; pp. 935-41.
- (12) Karas, M.; Bachmann, D.; Bahr, U.; Hillenkamp, F. *Int. J. Mass Spectrom. Ion Proc.* **1987**, *78*, 53-68.
- (13) Tanaka, K.; Waki, H.; Ido, Y.; Akita, S.; Yoshida, Y.; Yoshida, T. *Rapid Commun. Mass Spectrom.* **1988**, *2*, 151-53.
- (14) Karas, M.; Hillenkamp, F. *Anal. Chem.* **1988**, *60*, 2299-301.
- (15) Karas, M.; Bahr, U. *Trends Anal. Chem.* **1990**, *9*, 321.
- (16) Sundqvist, B.U.R.; Kamensky, I.; Hakansson, P.; Kjellberg, J.; Salehpour, M.; Widdiyasekera, S.; Fohlman, J.; Peterson, P. A.; Roepstorff, P. *Biomed. Mass Spectrom.* **1984**, *11*, 242.
- (17) Bolbach, G.; Della-Negra, S.; Deprun, C.; Le Beyec, Y.; Standing, K. G. *Rapid Commun. Mass Spectrom.* **1987**, *1*, 22.
- (18) Chait, B. T.; Standing, K. G. *Int. J. Mass Spectrom. Ion Phys.* **1981**, *40*, 185.
- (19) Mamyrin, B. A.; Karataev, V. I.; Shmikk, D. V.; Zagulin, V. A. *Sov. Phys. JETP* **1973**, *37*, 45.
- (20) Feigl, P.; Schueler, B.; Hillenkamp, F. *Int. J. Mass Spectrom. Ion Phys.* **1983**, *47*, 15.
- (21) Beavis, R. C.; Chait, B. T. *Rapid Commun. Mass Spectrom.* **1989**, *3*, 233.
- (22) Salehpour, M.; Perera, I.; Kjellberg, J.; Hedin, A.; Islamian, M. A.; Hakansson, P.; Sundqvist, B.U.R. *Rapid Commun. Mass Spectrom.* **1989**, *3*, 259.
- (23) Nelson, R. W.; Rainbow, M. J.; Lohr, D. E.; Williams, P. *Science* **1989**, *246*, 1585.
- (24) Spengler, B.; Cotter, R. J. *Anal. Chem.* **1990**, *62*, 793.
- (25) Ens, W. E.; Mao, Y.; Meyer, R.; Standing, K. G. *Rapid Commun. Mass Spectrom.* **1991**, *5*, 117.
- (26) Beuhler, R. J. *J. Appl. Phys.* **1983**, *54*(7), 4118-26.
- (27) Spengler, B.; Kirsch, D.; Kaufmann, R.; Karas, M.; Hillenkamp, F.; Giessmann, U. *Rapid Commun. Mass Spectrom.* **1990**, *4*, 301-05.
- (28) Strupat, K.; Karas, M.; Hillenkamp, F. *Int. J. Mass Spectrom. Ion Proc.*, in press.
- (29) Beavis, R. C.; Chait, B. T. *Anal. Chem.* **1990**, *62*, 1836.
- (30) Overberg, A.; Hassenburger, A.; Hillenkamp, F. In *Mass Spectrometry in the Biological Sciences: A Tutorial*; Gross, M. L., Ed.; Kluwer Academic Publishers, in press.
- (31) Mayer, F. J.; Holle, A.; Schafer, R.; Frey, R. *Advances in Mass Spectrometry*; Elsevier: Amsterdam, in press.
- (32) Henderson, L. E.; Oriszlan, S.; Konigsberg, W. *Anal. Biochem.* **1979**, *93*, 153.
- (33) (a) Beavis, R. C.; Chait, B. T. In *Methods and Mechanisms for Producing Ions from Large Molecules*; Ens, W.; Standing, K. G., Eds.; NATO ASI series; in press. (b) Spengler, B.; Kirsch, D.; Kaufmann, R. *Rapid Commun. Mass Spectrom.* **1991**, *5*, 198-202.
- (34) Horiuchi, A.; Williams, K. R.; Kurihara, T.; Nairn, A. C.; Greengard, P. J. *J. Biol. Chem.* **1990**, *265*, 9476-84.
- (35) (a) Weber, K.; Osborn, M. J. *J. Biol. Chem.* **1969**, *224*, 4406-12. (b) Laemmli, U. K. *Nature*, **1970**, *227*, 680-85.
- (36) Beavis, R. C.; Chait, B. T. *Rapid Commun. Mass Spectrom.* **1989**, *3*, 432-35.
- (37) Beavis, R. C.; Chait, B. T. *Proc. Natl. Acad. Sci. USA* **1990**, *68*, 73-77.
- (38) Gotto, A. M.; Pownall, H. J.; Havel, R. J. *Methods Enzymol.* **1982**, *128*, 3-41.
- (39) Caprioli, R. M.; Whaley, B.; Mock, K. K.; Cottrell, J. S. In *Techniques in Protein Chemistry II*; Villafranca, J., Ed.; Academic Press: New York, 1991; p. 497.
- (40) Schar, M.; Bornsen, K. O.; Gassman, E. *Rapid Commun. Mass Spectrom.* **1991**, *5*, 319-26.
- (41) Goldberg, D. E.; Slater, A.F.G.; Beavis, R. C.; Chait, B. T.; Cerami, A.; Henderson, G. B. *J. Exp. Med.* **1991**, *173*, 961-69.
- (42) Hillenkamp, F.; Karas, M.; Ingendoh, A.; Stahl, B. In *Biological Mass Spectrometry*; Burlingame, A. L.; McCloskey, J. A., Eds.; Elsevier: Amsterdam, 1990; pp. 49-60.
- (43) Stahl, B.; Steup, M.; Karas, M.; Hillenkamp, F. *Anal. Chem.* **1991**, *63*, 1463-66.
- (44) Mock, K. K.; Davey, M.; Cottrell, J. S. *Biochem. Biophys. Res. Commun.* **1991**, *177*, 644-51.

